

DUBHE PRODUCTS PROFILE

SHANGHAI DUBHE ENVIRONMENTAL PROTECTION&TECHNOLOGY CO.,LTD

Room 428, No.255 Xinjinqiao Road, Pudong District, Shanghai, China

Date:2023/09/12 Tel:(Amber)+8618019736003 Email:shdubhe@gmail.com

Website:<https://www.shdubhe.com>

Introduction of DUBHE

Founded in Shanghai in 2019, Shanghai DUBHE Environmental Protection & Technology Co., Ltd. is a comprehensive service provider of environmental equipment and technical services mainly serving large-scale water companies such as BEWG, CITIC Environment Water, etc., and providing high-quality technical solutions and ancillary equipment for a long time.

The main sales products for sewage treatment equipment, mixing and pushing the flow of equipment, solid-liquid separation equipment, sewage desliming machine equipment, land-based pumps, submersible pumps, units, membrane components, aeration disk and other products. Products are located in the high-end market, used in large-scale municipal sewage plants, industrial wastewater treatment.

Shanghai DUBHE also acts as an agent for some famous brands at home and abroad, such as Taiwan Yuan CX sludge dewatering machine, South Korea Shiya air floatation fan, BiNuo super sludge drying machine, Bollyuan pump fan, etc. integrating domestic and foreign high-quality equipment resources to provide customers with multi-faceted choices.

In response to market trends and needs, the company has laid out from "equipment supplier" to "sewage treatment total solution provider" upgrade development, the formation of Taiwan water treatment experts mainly R&D and design departments, for sewage treatment to provide technical diagnosis, Upgrading transformation, equipment manufacturing and sales, and other comprehensive services. In the face of the future, DUBHE will continue to uphold the "optimal product, customer win-win" business philosophy, to provide customers with higher quality products and better service.



Here are our certificates





Sludge Dehydrator

<p>DTB 转鼓浓缩脱水机(标准型) DTB Rotary Drum Thickeners</p> 	<p>DTB3三滤带重力浓缩脱水一体机 (标准型) DTB3 Three Filter Belt Type Gravity Belt Thickening</p> 	<p>TS水切楔形网固液分离机 TS Water cutting wedge solid liquid separator</p> 
<p>滤布宽度 (Belt Width):500-2500mm 污泥处理量(Treating Capacity):2.8-56m³/hr 绝干量 (Dried Sludge): 45-70kg/hr 主要材质(Material):SUS304 参考重量 (Reference Weight):950-3850kg</p> <p>用途: 适用于市政污水厂、工矿企业污水厂、食品和饮料化工和制药工业等污水处理系统的平流式沉淀池, 刮除池底沉淀物及水面浮渣。</p> <p>Application: It is suitable for advection sedimentation tanks in sewage treatment systems such as municipal sewage plants, industrial and mining enterprise sewage plants, food and beverage chemical and pharmaceutical industries, etc. To scrape bottom sediment and surface scum.</p>	<p>滤布宽度 (Belt Width):500-2500mm 污泥处理量(Treating Capacity): 2.8-56m³/hr 绝干量 (Dried Sludge):42-450kg/hr 主要材质(Material): SUS304 参考重量 (Reference Weight):1600-5660kg</p> <p>用途: 废水扬升站, 都市废水处理厂。 楼化粪池排水系统, 农畜牧业废水处理系统。 医院、学校、社区等生活废水处理系统。</p> <p>Application: Wastewater lift station; Municipal wastewater treatment plant; Building wastewater treatment system Animal & poultry farm wastewater treatment system; wastewater treatment system for hospital, school, community etc.</p>	<p>功率(power):2.2-3KW 水处理量(Treating Capacity): 5-10t 主要材质(Material): SUS304 最大处理量 (solid):2.5m³/h</p> <p>用途: 都市废水处理厂, 楼化粪池排水系统, 农畜牧业废水处理系统。医院、学校、社区等生活废水处理系统。</p> <p>Application: Municipal wastewater treatment plant; Building wastewater treatment system Animal & poultry farm wastewater treatment system; wastewater treatment system for hospital, school, community etc.</p>
<p>DHNS 转鼓浓缩机 DHNS Rotary Drum Thickeners</p> 	<p>TSDL 叠螺机 TSDL Multi-Disk Screw Press</p> 	<p>DHBT 滤带式浓缩机 DHBT Belt Thickeners</p> 
<p>污泥处理量(Treating Capacity): 30-80m³/hr 绝干量(Dried Sludge): 40-1250kg/hr 材质(Material): SUS304 参考重量 (Reference Weight): 300-2560kg</p> <p>用途: 大楼地下排放设备、下水道排水工程、土木工程、污水排放。</p> <p>Application: The base of building drainage equipment and sewer drainage works. Civil and architectural engineering construction. Cabin ponding and wastewater drainage.</p>	<p>污泥处理量 (Treating Capacity): 2.5-12.8m³/hr 绝干量 (Dried Sludge):10-640kg/hr 材质 (Material):SUS304</p> <p>用途: 都市废水处理厂。 楼化粪池排水系统, 农畜牧业废水处理系统。 医院、学校、社区等生活废水处理系统。</p> <p>Application: Municipal wastewater treatment plant; Building wastewater treatment system Animal & poultry farm wastewater treatment system; Wastewater treatment system for hospital, school, community etc.</p>	<p>污泥处理量 (Treating Capacity): 30-125m³/hr 绝干量 (Dried Sludge):120-1313kg/hr 参考重量 (Reference Weight): 1250-2700kg 材质(Material):SUS304</p> <p>用途: 都市废水处理厂。 楼化粪池排水系统, 农畜牧业废水处理系统。 医院、学校、社区等生活废水处理系统。</p> <p>Application: Municipal wastewater treatment plant; Building wastewater treatment system Animal & poultry farm wastewater treatment system; Wastewater treatment system for hospital, school, community etc.</p>

Sludge Dehydrator

DTE转鼓浓缩脱水机（重载型） Rotary Drum Thickeners (High-duty Type)	DTE3三滤带重力浓缩脱水机（重载型） Three Filter Belt Gravity Belt Thickening	高压深度脱水机 High-pressure Belt Filter Press
		
<p>滤布宽度 (Belt Width): 750-3000 mm 污泥处理量(Treating Capacity):2.8-56m³/hr 绝干量 (Dried Sludge): 105-1260kg/hr 主要材质(Material):SUS304 参考重量 (Reference Weight):1400-5400kg</p> <p>用途: 适用于市政污水厂、工矿企业污水厂、食品和饮料化工和制药工业等污水处理系统的平流式沉淀池，刮除池底沉淀物及水面浮渣。</p> <p>Application: It is suitable for advection sedimentation tanks in sewage treatment systems such as municipal sewage plants, industrial and mining enterprise sewage plants, food and beverage chemical and pharmaceutical industries, etc. to scrape bottom sediment and surface scum.</p>	<p>滤布宽度 (Belt Width): 750-3000 mm 污泥处理量(Treating Capacity):14.0-130m³/hr 绝干量 (Dried Sludge): 96-1250kg/hr 主要材质(Material):SUS304 参考重量 (Reference Weight):1680-5900kg</p> <p>用途: 适用于市政污水厂、工矿企业污水厂、食品和饮料化工和制药工业等污水处理系统的平流式沉淀池，刮除池底沉淀物及水面浮渣。</p> <p>Application: It is suitable for advection sedimentation tanks in sewage treatment systems such as municipal sewage plants, industrial and mining enterprise sewage plants, food and beverage chemical and pharmaceutical industries, etc. to scrape bottom sediment and surface scum.</p>	<p>滤布宽度 (Belt Width): 1000-3000 mm 污泥处理量(Treating Capacity):5.0-90m³/hr 绝干量 (Dried Sludge): 76-1250kg/hr 主要材质 (Material):SUS304 参考重量 (Reference Weight):3150-9800kg</p> <p>用途: 适用于市政污水厂、工矿企业污水厂、食品和饮料化工和制药工业等污水处理系统的平流式沉淀池，刮除池底沉淀物及水面浮渣。</p> <p>Application: It is suitable for advection sedimentation tanks in sewage treatment systems such as municipal sewage plants, industrial and mining enterprise sewage plants, food and beverage chemical and pharmaceutical industries, etc. to scrape bottom sediment and surface scum.</p>



Bubble Air Diffuser

DUDH 微孔曝气盘 DUDH Fine Bubble Disc Diffuser	DUDS 锥型曝气盘 DUDS Cone Diffuser	DUTH 曝气管 DUTH Tube Diffuser
		
<p>尺寸(size): 7-12 inch 气流(run flow):1.0-4.5 m³/hr 有效面积(service area): 0.3-1m²/pcs 气泡直径(bubble size):1-2mm 气孔量(hole quantity):3500-8000 使用年限(service life):≥5</p> <p>用途: 曝气盘广泛应用于污水处理厂、鱼塘、水生态系统和人工湖泊等水体中，水族箱和水生植物栽培中</p> <p>Application: Aeration trays are widely used in wastewater treatment plants, fish ponds, aquatic ecosystems and artificial lakes, aquariums and aquatic plant cultivation..</p>	<p>功率(power):0.37-90 kw 气流(run flow):1.0-4.5m³/hr 有效面积(service area): 0.3-1m²/pcs 气泡直径(bubble size):1-2mm 气孔量(hole quantity):3500-8000 使用年限(service life):≥5</p> <p>用途: 曝气盘广泛应用于污水处理厂、鱼塘、水生态系统和人工湖泊等水体中，水族箱和水生植物栽培中</p> <p>Application: Aeration trays are widely used in wastewater treatment plants, fish ponds, aquatic ecosystems and artificial lakes, aquariums and aquatic plant cultivation.</p>	<p>有效面积(service area) :0.8-1.2m² 通气量(airflow):5-10m³/hr 气孔密度(stomatal density):14000-15000/pcs 氧利用率(oxygen utilization):18.4-27.7/%</p> <p>用途: 曝气管广泛应用于污水处理过程中，特别是在活性污泥法中；水体增氧：曝气管在水体增氧方面也具有重要作用；混合搅拌：曝气管也可用于水体的混合搅拌</p> <p>Application: Aeration tubes are widely used in the sewage treatment process, especially in the activated sludge method; water oxygenation: aeration tubes also play an important role in water oxygenation; mixing and stirring: aeration tubes can also be used for mixing and stirring of the water; bioreactors and fermentation processes.</p>

Water Treatment Filler

PSS/TSS 斜板/管填料 PSS/TSS Slant Plate/Tube Filler	MBBR填料 MBBR Moving Bed Biofilm Reactor	生物绳填料 Bio cord
		
<p>直径(diameter):25-80mm 重量(weight)25-35kg/m² 有效面积(effective area)50-116m²</p> <p>用途 斜管主要适用于进水口除砂，一般工业和生活给水沉淀、污水沉淀、隔油以及尾张浓缩等处理，即适用于新建工程，又适用于现有旧池的改造。</p> <p>Application: Inclined tube is mainly used in the inlet to remove sand, general industrial and domestic water supply precipitation, sewage precipitation, oil separation and tail sheet concentration and other treatments, that is, suitable for new construction, but also suitable for the transformation of the existing old pools.</p>	<p>材料(Material): HDPE 有效面积(Effective Surface): > 500m² 重量(Specific Gravity): > 0.96g/cm³ PH值: 5-11 温度(Temperature):35-65°C 使用年限(life): ≥15Y</p> <p>用途 污水处理MBBR与生物滤池工艺载体；中水回用；生活污水回用生物处理杂排水回用生物处理；河道治理 脱氮、除磷、脱碳，净化水质；</p> <p>Application: Wastewater treatment MBBR with biofilter process carrier; water reuse; domestic sewage reuse biological treatment of miscellaneous drainage water reuse biological treatment ; River treatment Nitrogen removal, phosphorus removal, decarbonization, water purification.</p>	<p>抗压力(pressure-resistant): 95% 重量(weight): 3.2kg/cm³ 磨损率(Wear rate): 0.89-1.12% 密度(density): 0.9-1.1</p> <p>用途 生物绳填料广泛应用于生物滤池，污水处理系统，水产养殖，水体修复和生态系统恢复。</p> <p>Application: Bio-rope fillers are widely used in biofilters, wastewater treatment systems, aquaculture, water remediation and ecosystem restoration.</p>

Membrane Bio-Reactor

DEM平板膜组件 Flat Membrane Bio-Reactor products	外压式中空纤维超滤膜产品 External pressure hollow fiber ultrafiltration membrane product	DEM-TM 管式膜组件 Tubular Membrane Bio-Reactor
		
<p>有效膜面积(Effective area): 0.1-1.5m² 处理水量(Treated water):23-68(m³/d) 出水浊度(Turbidity of effluent)<1 框架材质(Frame Material):Stainless steel 304 集水管接口尺寸(Catchpipe Connection Size):DN50/32 重量(Weight):320-700kg</p> <p>用途: 市政污水回用;生活污水一体化设备;黑臭水体治理;印染废水处理;化工废水处理;食品饮料废水处理。</p> <p>Application: Municipal wastewater reuse; Domestic Wastewater Integration Equipment; Black Odor Water Treatment; Printing and dyeing wastewater treatment; Chemical wastewater treatment; Food and beverage wastewater treatment.</p>	<p>膜材质(Material): Polyvinylidene Fluoride 平均孔径(Average pore diameter):30nm 出水浊度(Turbidity of Effluent)≤0.5NTU 产水量(Water Yield):≤5 入口压力(Inlet Pressure):≤6.25kpa</p> <p>用途: 市政污水回用; 自来水厂水净化;化工废水处理及回用;海水淡化预处理; 炼油废水深度处理;焦化废水深度处理。</p> <p>Application: Municipal wastewater reuse; water purification for waterworks; chemical wastewater treatment and reuse; seawater desalination pre-treatment; oil refining wastewater deep treatment; coking wastewater deep treatment.</p>	<p>膜管直径(diameter): 8mm 外壳材料(Shell material): PVC or fiberglass 核心数(core number): 37-365 工作温度(Maxi Temperature): 45-90°C 纯水通量(Pure Water Flux):100-2000L/m²/hr</p> <p>用途: 垃圾渗滤液; 焦化水; 高硬度废水脱硬;含油废水; 市政污水回用; 食品与饮品。</p> <p>Application: Waste leachate; coker water; high hardness wastewater dehardening; oily wastewater; municipal wastewater reuse; food & beverage.</p>

SSI Aeration Disc DUBHE Agent

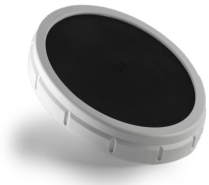

AFD-270E



AFD-270P



AFD-350



ECD270



ECD270

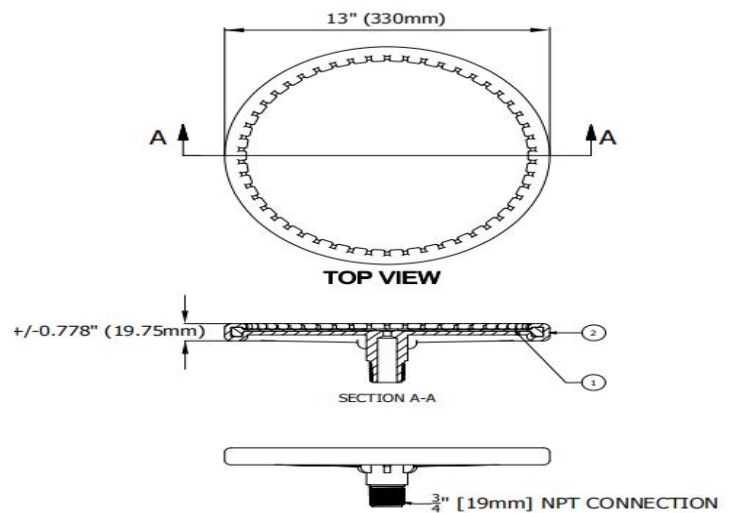
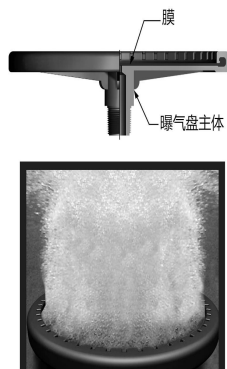

ECD350

